

# GROUND 10 SQ90



## ΠΕΡΙΕΧΟΜΕΝΑ / CONTENTS

|           |   |
|-----------|---|
| datasheet | 1 |
| manual    | 2 |

## ΚΩΔΙΚΟΣ / CODE

**G10S90** - XX-XX-XX-XX-XX-XX-XX-XX-XX

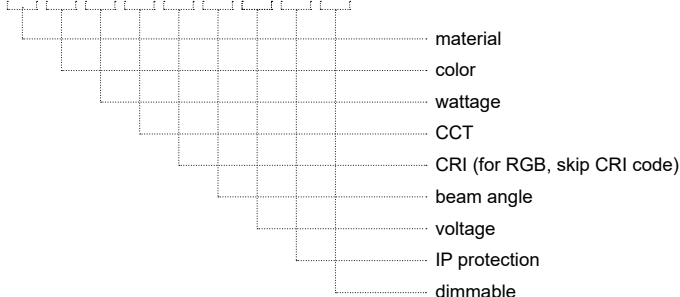

## GROUND 10 SQ90 (G10S90) / Datasheet

To καύτι τοποθέτησης περιλαμβάνεται / Installation box is included

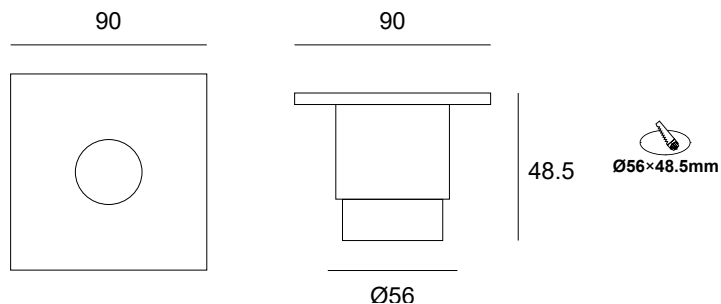

### General information

|                            |                                   |
|----------------------------|-----------------------------------|
| Application                | Outdoor / Recessed                |
| Direction of mounting      | Ceiling / Wall / Ground           |
| LED                        | Cree / Osram                      |
| Life time                  | 50000 hrs                         |
| Warranty                   | 3-5 years (*5 years upon request) |
| Origin                     | Greece                            |
| Visible dimensions (W×H×L) | 90 × 90 × 48.5 mm                 |
| Installation               | Recessed installation box         |

| Material       | Color         | Wattage         | CCT                | CRI         | Beam angle   | Voltage     | IP          | Dimmable  |
|----------------|---------------|-----------------|--------------------|-------------|--------------|-------------|-------------|-----------|
| Aluminium (01) | Anodised (AN) | 1W (1W)         | 2700K (27K)        | Ra80 (80)   | Diffuse (DF) | 12VDC (V1)  | IP20 (20)   | Yes (D)   |
| Inox (02)      | Black (BL)    | 2W (2W)         | 3000K (30K)        | Ra90 (90)   | 8° (8D)      | 24VDC (V2)  | IP54 (54)   | No (L)    |
| Brass (03)     | White (WH)    | 2.5W (25W)      | 4000K (40K)        |             | 15° (15D)    | 230VAC (V3) | IP65 (65)   |           |
|                |               | RAL colors (RL) | 3W (3W)            | 5000K (50K) |              | 20° (20D)   | 12/24V (V4) | IP67 (67) |
|                |               | 4W (4W)         | 6000K (60K)        |             | 25° (25D)    | 350mA (V5)  | IP68 (68)   |           |
|                |               | 6W (6W)         | (R)/(G)/(B)/(A)    |             | 36° (36D)    | 500mA (V6)  |             |           |
|                |               | 7W (7W)         | RGB (C1)           |             | 45° (45D)    | 700mA (V7)  |             |           |
|                |               |                 | RGBW (5W 24V) (C2) |             | 60° (60D)    |             |             |           |
|                |               |                 |                    |             | 80° (80D)    |             |             |           |

Δημιουργία Κωδικού προϊόντος / Product Code generator

**G10S90 - material - color - wattage - CCT - CRI - beam angle - voltage - IP - dimmable**  
 (ex. G10S90-01-AN-1W-27K-80-8D-V1-54-D for Ground 10 SQ90 Aluminium Anodised 1W 2700K Ra80 8° 12VDC IP54 Dimmable)

# GROUND 10 SQ90 / Manual

1. ΠΡΟΕΤΟΙΜΑΣΙΑ ΤΟΥ ΕΔΑΦΟΥΣ / PREPARATION OF TERRAIN
2. ΚΑΝΕΤΕ ΤΗΝ ΗΛΕΚΤΡΙΚΗ ΣΥΝΔΕΣΗ / MAKE THE ELECTRICAL CONNECTION
3. ΤΟΠΟΘΕΤΗΣΗ ΤΟΥ ΦΩΤΙΣΤΙΚΟΥ / PLACE THE LUMINAIRE (a. επιδαπέδια/ground | b. χωνευτο/recessed)

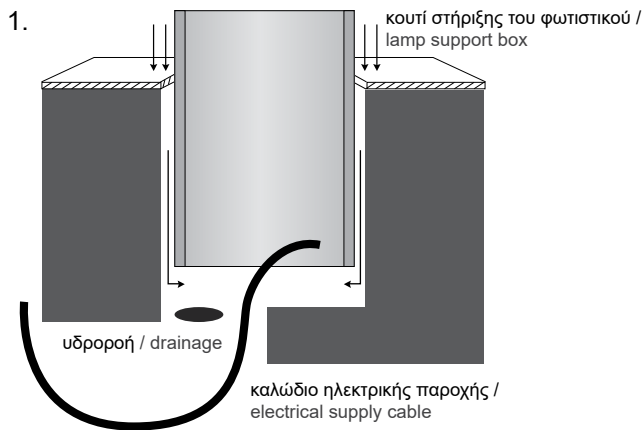

2.

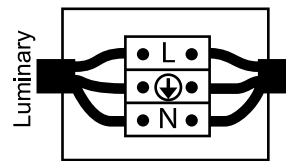

Συνδέστε το καλώδιο του φωτιστικού με την ηλεκτρική παροχή. Η σύνδεση πρέπει να είναι στεγανή. / Connect the cable of the luminaire with the electrical supply. The connection must be sealed.

3.a Εφαρμογή στο έδαφος με O-ring / Application on ground using O-ring

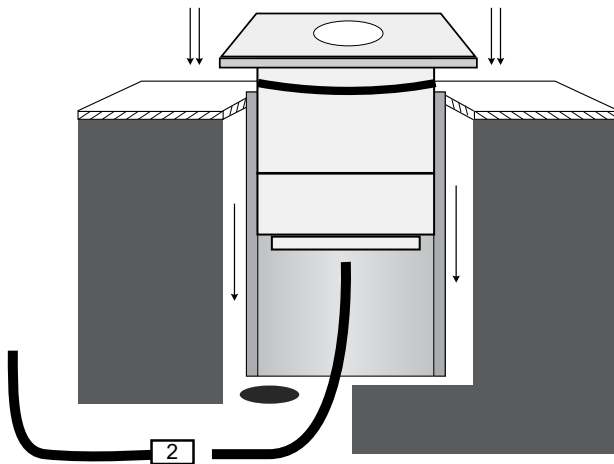

Εφαρμόστε το φωτιστικό στο κουτί εγκατάστασης μέχρι να σφινώσει και να σταθεροποιηθεί. / Apply the luminaire to the installation box until it is firm and stabilized.

3.b Εφαρμογή στον τοίχο με ελατήρια / Application on wall using springs

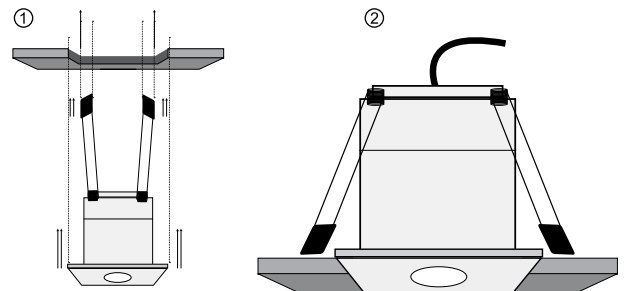

① Κρατήστε τα ελατήρια προς τα πίσω για να περάσουν πρώτα αυτά από την οπή και έπειτα ② αφήνετε το φωτιστικό σιγά σιγά μέχρι να εφαρμόσει στην οροφή. / ① Hold the springs backwards to get them through the cutter first and then ② slowly leave the lamp until it applies into the roof.