

# LINEAR LED GROUND 35

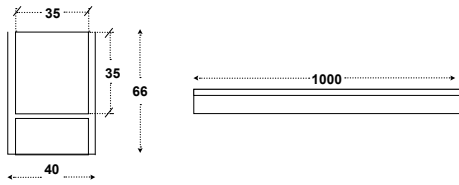

24V DC

S / M / W

1200gr



IP68

## ΟΔΗΓΙΕΣ ΕΓΚΑΤΑΣΤΑΣΗΣ // INSTALLATION INSTRUCTIONS

1. ΠΡΟΕΤΟΙΜΑΣΙΑ ΤΟΥ ΕΔΑΦΟΥΣ / PREPARATION OF TERRAIN
2. ΚΑΝΕΤΕ ΤΗΝ ΗΛΕΚΤΡΙΚΗ ΣΥΝΔΕΣΗ / MAKE THE ELECTRICAL CONNECTION
3. ΤΟΠΟΘΕΤΗΣΗ ΤΟΥ ΦΩΤΙΣΤΙΚΟΥ / PLACE THE LUMINAIRE

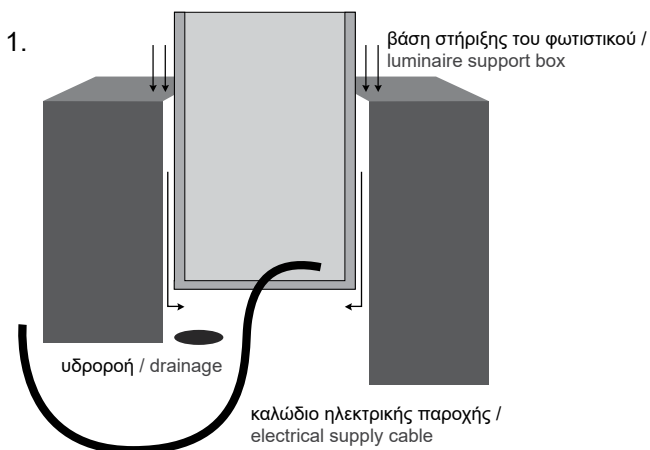

2.

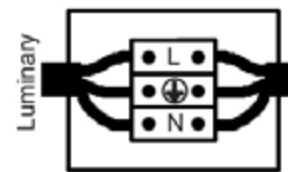

Συνδέστε το καλώδιο του φωτιστικού με την ηλεκτρική παροχή.  
Η σύνδεση πρέπει να είναι στεγανή. /  
Connect the cable of the luminaire with the electrical supply.  
The connection must be sealed.

## APPLICATION

3.

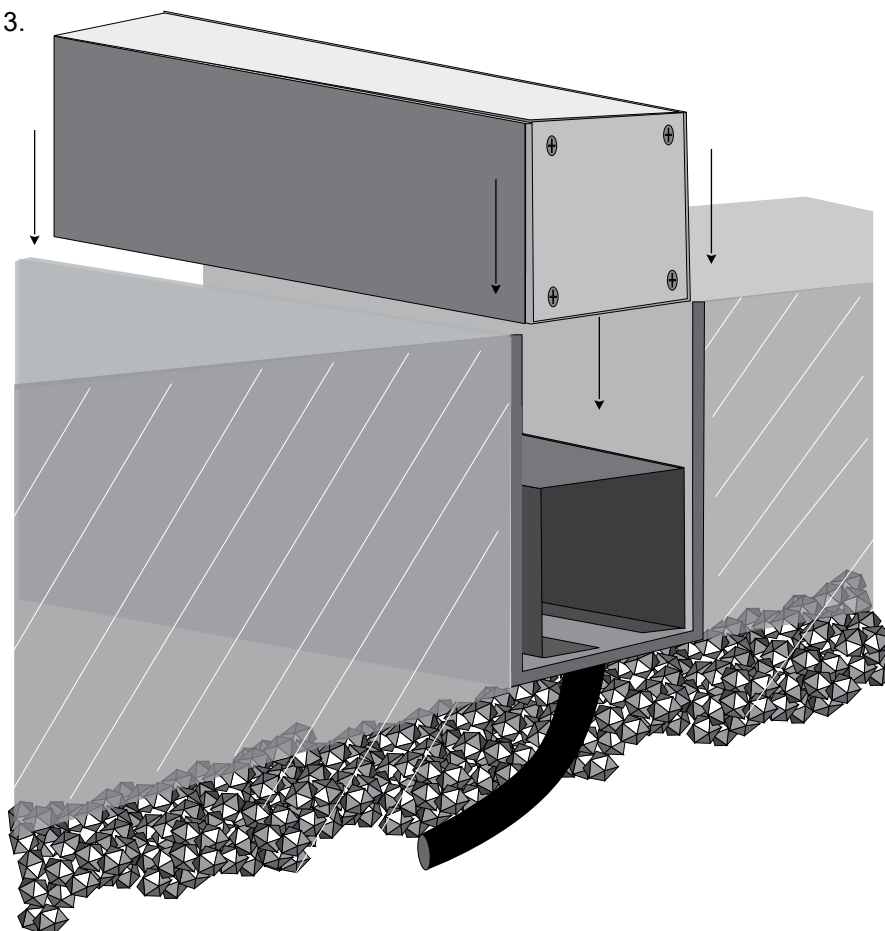

Εφαρμόστε το φωτιστικό στην βάση μέχρι να σταθεροποιηθεί /  
Apply the luminaire in its ground base  
until it is stable in its base

# LINEAR LED GROUND 35

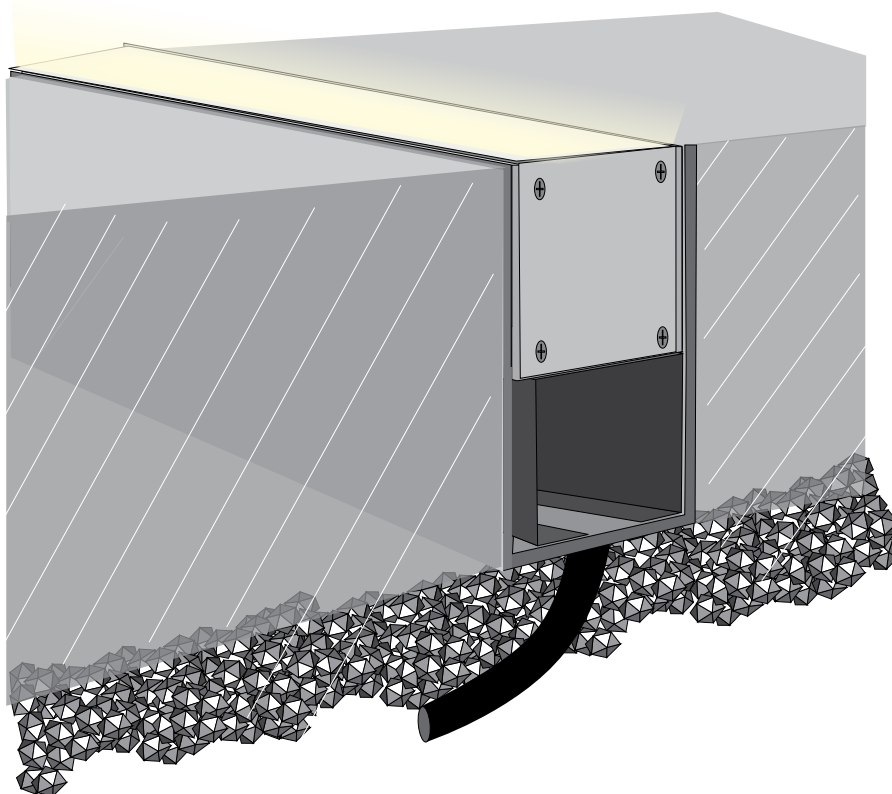

Μόλις εφαρμοστεί, το φωτιστικό είναι  
έτοιμο για την χρήση του /  
Once the luminaire is applied, it is  
ready to be used