

Parts needed to assemble and mount the FI-10-ZM-P fastener

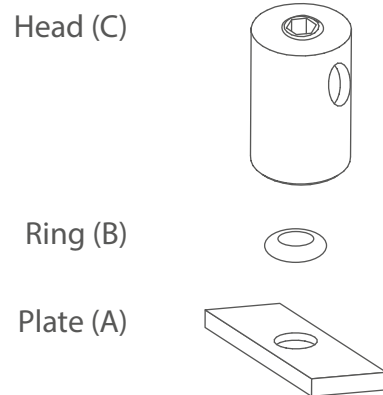

Tools needed for mounting:

- Allen wrench

NOTE! A list of products that can be used with the selected accessories is available at klusdesign.eu.

1. Mount the fastener in the chosen profile by inserting the plate (A) into the small lock on the back of the extrusion. Adjust the position of the head (C) by turning it closer to or further from the ring (B).

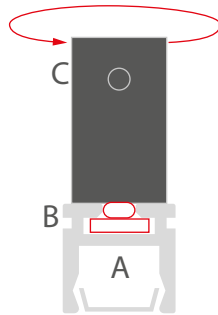

2. Insert the rod into the head (C). Lock it by turning the pressure screw of the head with the Allen wrench.

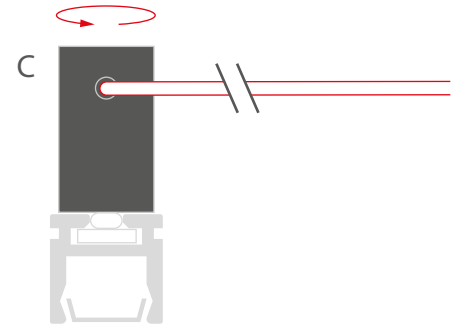

3. Mount the lighting fixture on the chosen mounting system.

